

DECO CAPE

Napa Rectangular Picnic Table Assembly Instructions

Note: these instructions are good for all sizes of Napa Rectangular Picnic Tables.

Items included:

- (1) Picnic Table Top
- (2) Picnic Table Benches
- (2) X-legs
- (32) bolts
- (32) washers

Items required:

- 3/8" hex socket
- Power drill
- Optional: clamps

(2) people are recommended for this assembly. A workbench or level working surface is required. Estimated assembly time: 15 minutes per table.

Instructions:

1. Place tabletop upside down on work surface (aluminum structure facing upwards).
2. Insert X-legs into tabletop aluminum framework, aligning leg rivet holes with tabletop frame holes. Drive bolts with washers through aluminum frame into rivet holes of X-legs (4 bolts per leg side). Repeat for other side.
3. Flip tabletop & legs around right side up. Place seats on each side of the X-leg seat supports, aligning seat frame holes with X-leg rivet holes. Drive bolts with washers through aluminum frame into rivet holes of X-legs (4 bolts per leg side). Repeat for other side and for other seat.

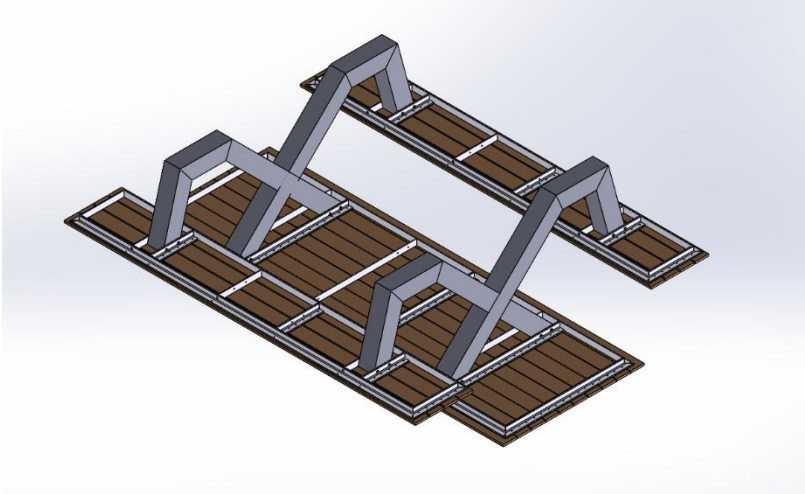

Figure 1: complete assembly, upside down.

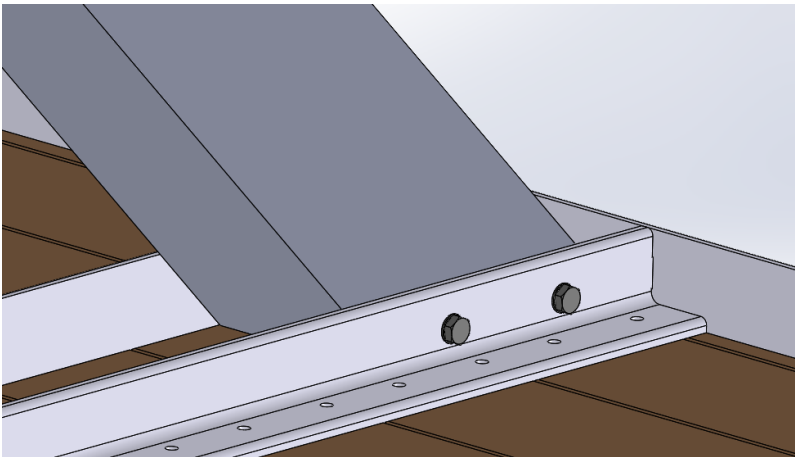

Figure 2: closeup of seat/leg connection.

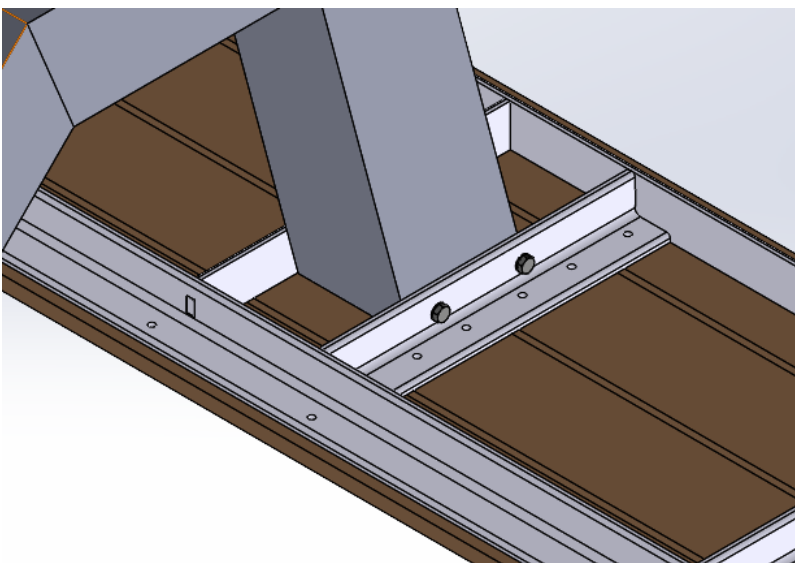

Figure 3: closeup of tabletop/leg connection.